



**FÉDÉRATION INTERNATIONALE DE SKI
INTERNATIONAL SKI FEDERATION
INTERNATIONALER SKIVERBAND**

TIMING-BOOKLET

Version 2.42

May 2007

With Homologated Timing Devices



Changes compared to Version 2.41

Page 6: (after System B): The use of any electronic device (e.g. optocoupler) between startgate and timer or photocell and timer must be specifically compatible and authorised by the manufacturers.

TABLE OF CONTENTS

FIS Alpine Timing Guide	3
Equipment Set-Up (see drawing).....	4
Timing without Cable Connection Between Start and Finish	7
Set-Up Diagram Level 0.....	8
Set-Up Diagram Level 1	9
Set-Up Diagram Level 2 (Cable).....	10
Set-Up Diagram Level 3 (Without Cable)	11
ICR 611 - Technical Installation	12
Start Gate.....	15
Photocell.....	17
“How-To” Explanation Text Timing Technical Report Form	19
details requested.	22
Chief of Timing and Technical Delegate:.....	22
Both have to confirm the given data by signing. Please give your e-mail address and phone number in case of questions! Timing Technical Report Form (example)	22
Timing Technical Report Form (example)	23
Criteria for FIS Approved Timing Devices for Alpine Ski Races.....	25
Conclusion	28

**Please check for the latest version of the FIS timing booklet
on the FIS website : www.fis-ski.com
(see Rules and Publication / Alpine Skiing / Alpine Timing)**

FIS Alpine Timing Guide

All timing devices used including Start Gates and photocells must be homologated as per the attached list. The most updated list can be found at the FIS website: <http://www.fis-ski.com/>

Races using devices not mentioned on that list will not be considered for FIS points.

Please note references to race Level classifications as listed here:

Category	Description	Level
OWG	Olympic Winter Games	0
WSC	FIS World Ski Championships	0
WC	FIS World Cup	0
WJC	FIS Junior World Championships	1
ANC	Australian New Zealand Cup	1
EC	European Cup	1
FEC	Far East Cup	1
NAC	Nor-Am Cup	1
SAC	South American Cup	1
UVS	Universiade	1
NC	National Championships	2
FIS	FIS Race	3
JUN	Junior Race	3
NJC	National Junior Championships	3
CIT	Citizen	3
UNI	University Race	3
CHI	Children	3
ENL	Entry Level	4

Cabling of a higher category can also be used.

Example: Level 2 can use same cabling as Level 1 or 0.

Equipment Set-Up (see drawing)

Cable connection

For Level 3 and 4 events, timing without cable connection from the start is permitted for both A and B timing systems. Refer to set-up diagrams that describe in detail how this may be effected.

Start

Starting Gate

Minimum of 2 electronically isolated contacts activated by 1 wand. Timing wires **①** & **②** must be connected to separate start gate contacts using separate connectors. The wand must be installed so that starting is impossible without it opening.

Start Clock

Can show time of day, and countdown status, but must have acoustic signal. Must be synchronized with the other timing systems. Use of such a start clock is highly recommended for all DH/SG and GS disciplines and is mandatory for use at event Levels 1 and 0.

Voice Communication **⑧**

Timing impulse and voice communication functions can be separated on different wire pairs if manufacturer's specifications dictate.

If radios are used for voice communication, a dedicated channel must be used.

Timing Cables

Make sure that cables cannot be torn out at the start by a competitor, or by any other person next to the starting area.

Cells at intermediate time

Locate Cells carefully in co-ordination with the Technical Delegate and/or the Race Jury.

To avoid the cells being triggered by anyone other than the competitors, it is recommended that the person responsible for that intermediate timing point use a push-button to arm the photocells only when a competitor crosses the line.

Cells at the finish line **③** & **④**

Please refer to the attached section that explains photocell use.

Wire must be used to connect photocells to the timer. Wireless is not allowed.

The use of a homologated timer with printer installed at the finish line directly attached to the photocells is recommended for Level 1 and Level 0 events or any time a lengthy wire connection to the finish area from the timing cabin is used.



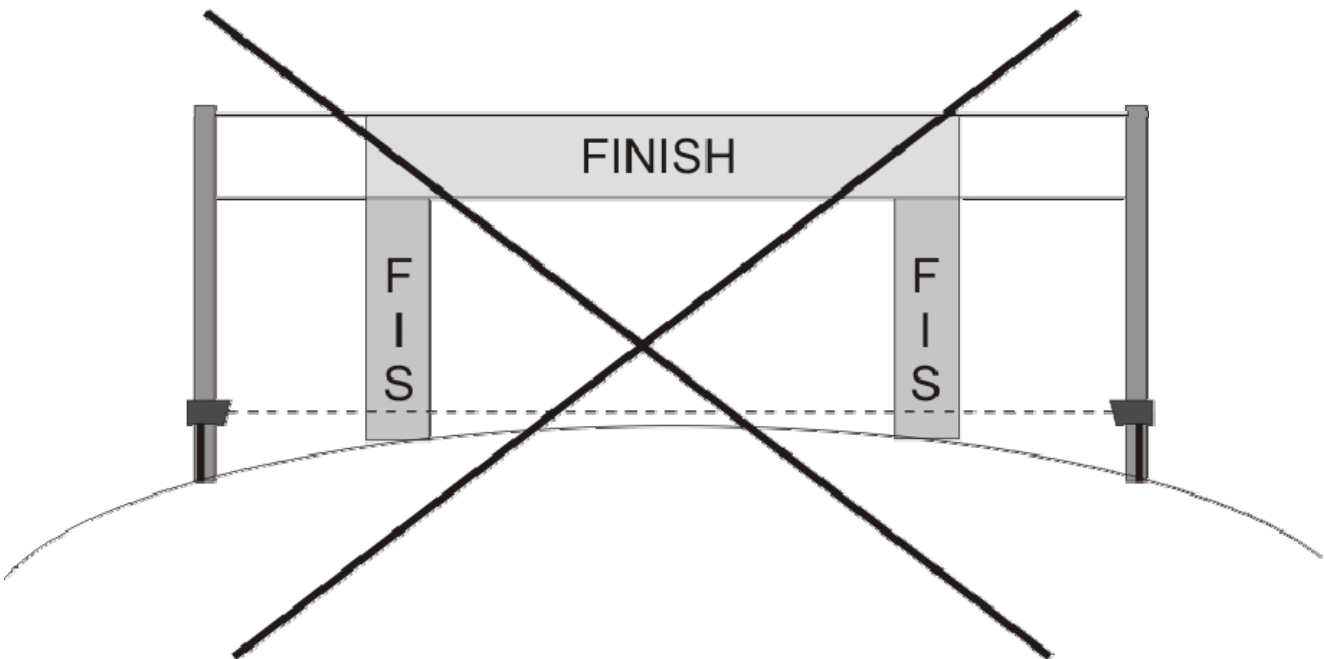
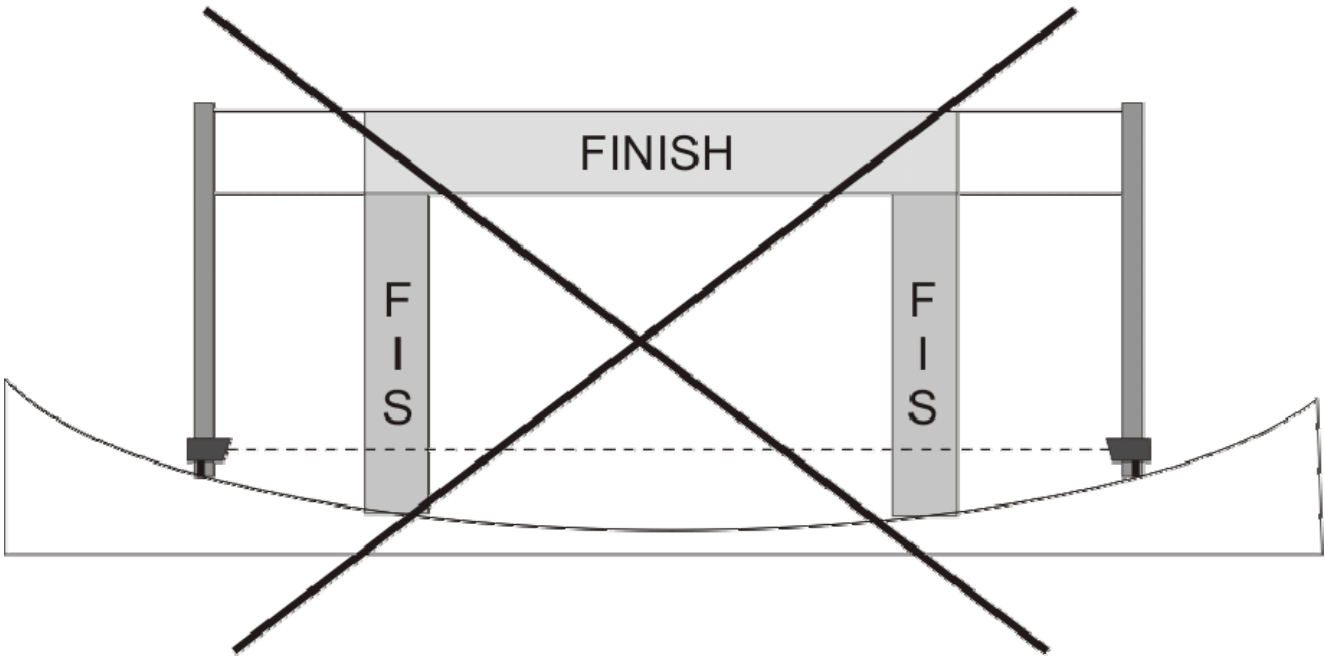
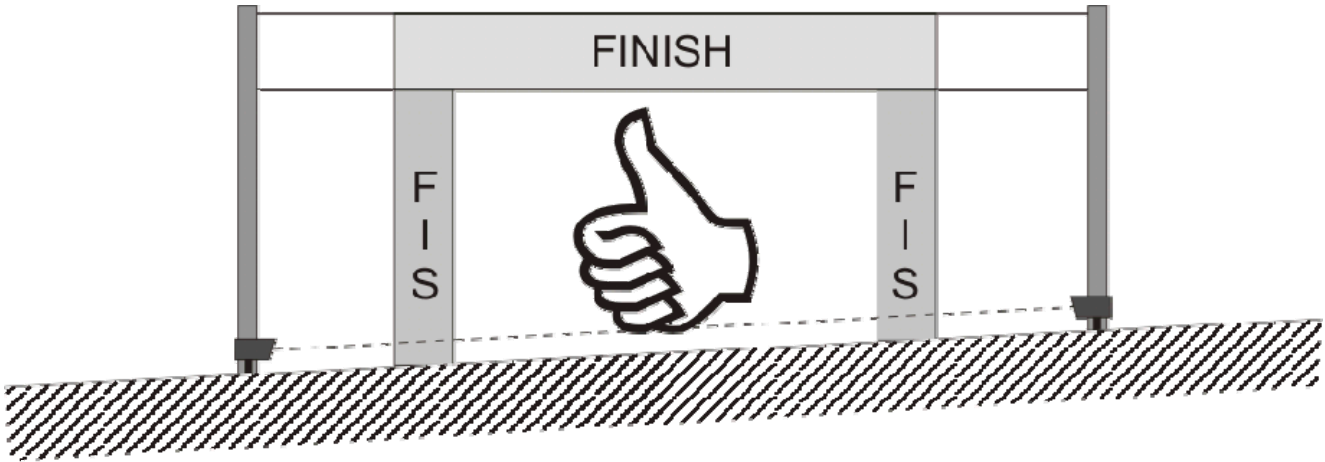

TIMING DEVICES

System A Timer ⑤

Start line ① and finish cell ③ must be connected.

System B Timer ⑥

Start line ② and finish cell ④ must be connected.

The use of any electronic device (e.g. optocoupler) between startgate and timer or photocell and timer must be specifically compatible and authorised by the manufacturers.

For Level 3 events only, when no hill cable between start and finish are installed homologated timers ⑨ must be used.

Manual hand timing ⑦

In all cases for all events at all levels, **hand timing is mandatory.**

Stopwatches, with or without printers, showing times to at least 1/100th second should be synchronised to the time of day and used at the start and at the finish.

A complete list of hand times recorded at the start and the finish must be given to the chief of timing at the end of each run, or immediately upon request.

Synchronisation

All elements of the timing installation, must be installed and be in good working order at least one hour before the beginning of the competition. Timers should be turned on 30 minutes before synchronisation to allow the quartz time bases to stabilise.

Synchronisation must be done no more than 60 minutes prior to the scheduled start of each run and must not be re-synchronised while the run is in progress.

The synchronisation impulse for all timers must come from the start gate or from one single contact switch for all timing devices. When using the startgate to make the sync impulse the start gate must be opened at a high speed (as in the race). One minute after synchronisation is done, a new impulse must be sent by the start gate or synchronising contact to check synchronisation accuracy on Systems A and B. The maximum allowed difference between system A and B is 0.005 seconds.

Should any important discrepancies be observed when this check is performed, synchronisation should be redone and checked again prior to the start of the run.

Manual stopwatch synchronisation must be done before or together with the synchronisation of the whole system.

Competition in progress

Reminders

In case of timing problems, the chief of timing must inform members of the jury or the finish referee immediately.

Starter and official timekeeper should agree upon using specific terms and commands during communication. This dialogue should be short and precise, as well as systematically repeated for each competitor. In all cases it is recommended that the starter always informs the timekeeper(s) at the finish before and after a competitor leaves the start.

At the end of each run or competition, before sending out the results, times and ranking from the timing systems and the computer results system must be compared and cross checked for accuracy

Notes

At the end of the competition, it is compulsory to give the Technical Delegate the enclosed "Timing Report Form", as well as the printed tapes from the System A, System B and all hand timing records.

A member of the Timing Working Group could check at any time and at any race the timing system connection. A contact of each starting line and finish photocell must be available to connect a FIS timing device. Of course, such connection will be done at least 2 hours before the race or training start and not during the race or training.

Timing without Cable Connection Between Start and Finish

The FIS Timing Working Group recognises the importance of allowing emerging and technically responsible technologies to be used in modern FIS events. For this reason, and because of the flexibility that it affords, FIS Level 3 and 4 events may use timing solutions that do not require any hard wire connection between start and finish for either A and/or B systems. Level 2,1 and 0 events are not allowed to use this solution.

Regardless of the technology being used, every solution without hill cable must include the use of 4 homologated timers operating in synchronised Time-of-Day with active printers. System A will be represented by one timer at the start and one timer at the finish. One timer at the start and one timer at the finish will represent system B.

All timing rules remain in force in this situation (set-up, synchronisation, time-of day precision, printing, hand timing). In addition, for race results to be valid the TD must gather and submit to the FIS all four timer printer tapes with the Timing Technical Report Forms.

The Chief of Timing must make certain that all timers and printers work in the physical environment of the start and finish regardless of the weather conditions and temperature particularly if the temperature is expected to be less than -10° C.

When a radio system with impulse transmission is used, every start time transmitted has a delay. This delay must be constant within $\pm 1/1000$ second. The delay must be clearly described in the manual of the radio system. Apply the FIS rules if a time from system B is used.

This allows race organisers to use many types of timing solutions without wires as long as these 4 timers are in place and are used to verify the results. If times are generated by a timing solution other than system A or B in all cases these times must be checked against system A and must match exactly. In case results deviate from system A, the events must be evaluated on the A system times as per the normal timing set-up rules and procedures.

Please refer to the set up diagram that illustrates the correct use of this technique.

Set-Up Diagram Level 0

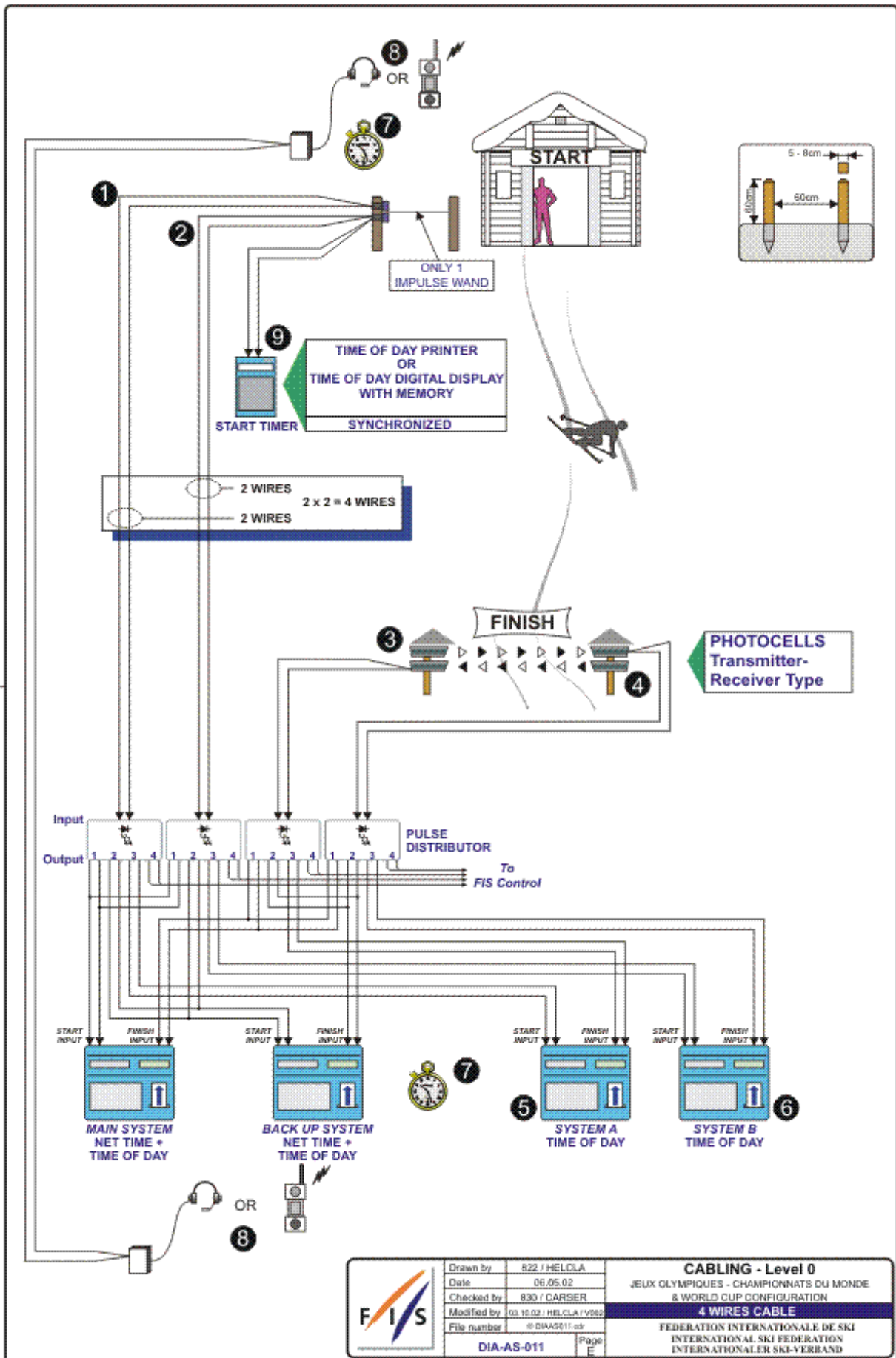

SUBJECT TO CHANGE WITHOUT NOTICE

Set-Up Diagram Level 1

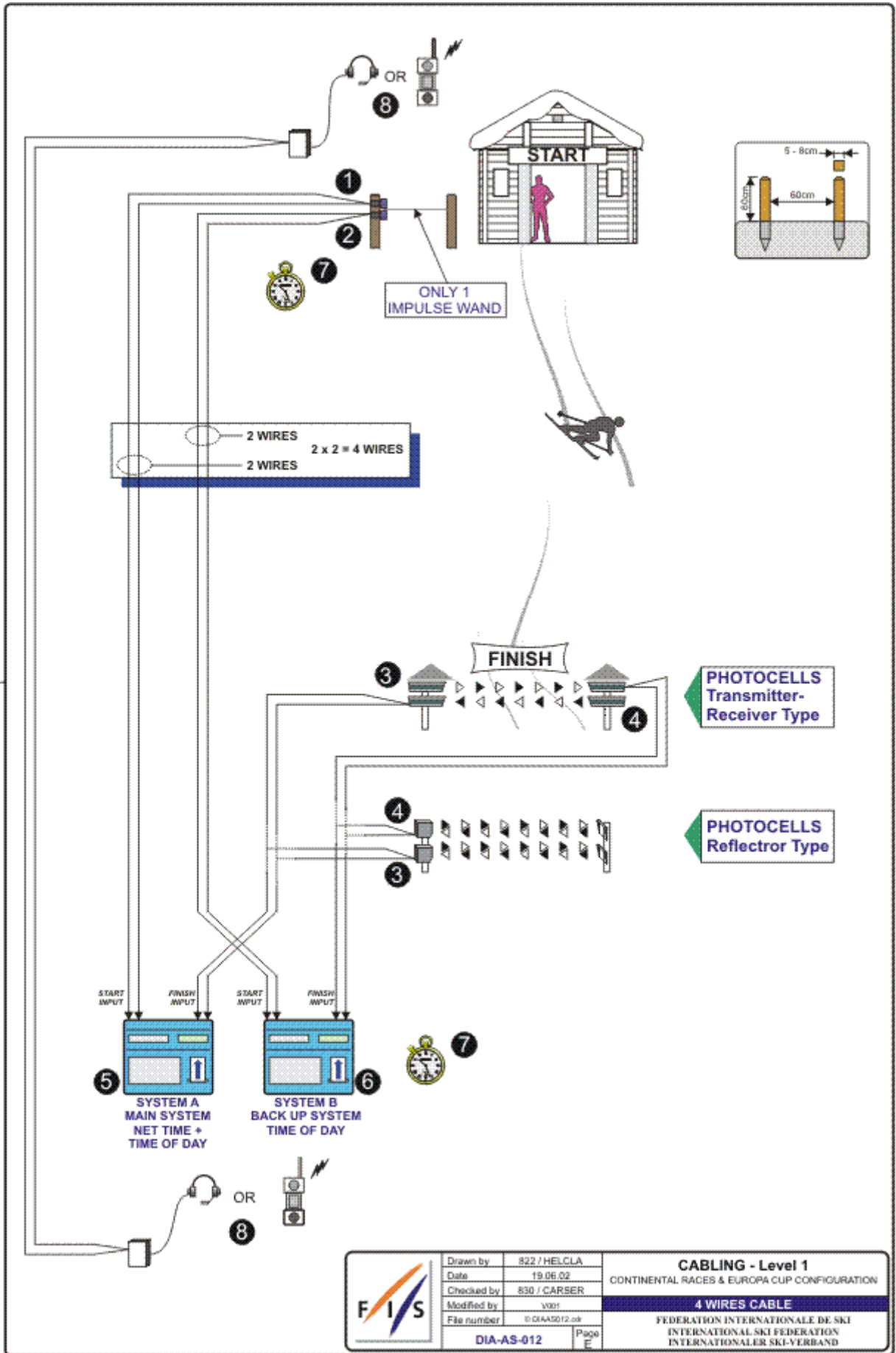

Set-Up Diagram Level 2 (Cable)

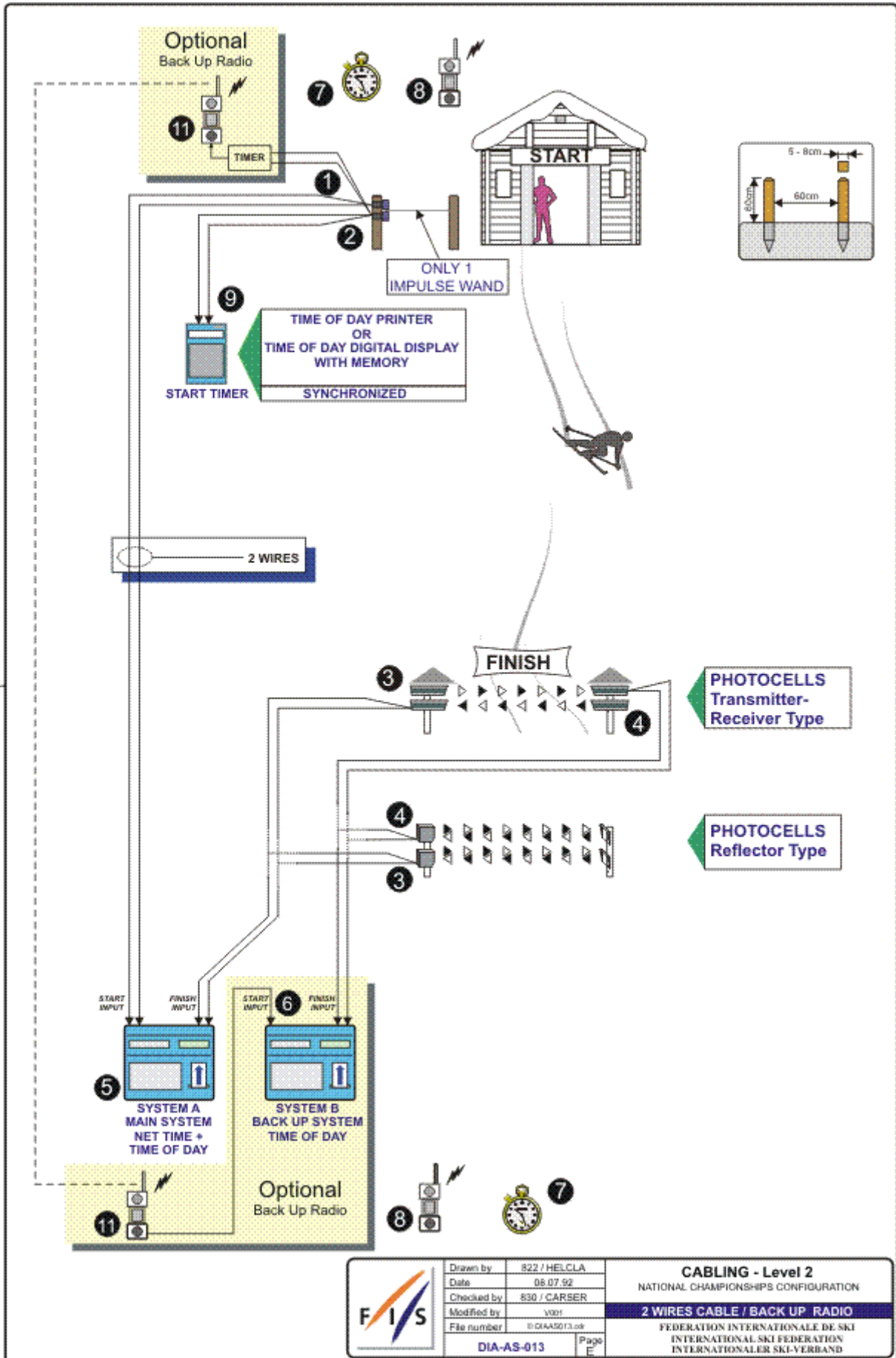

Set-Up Diagram Level 3 (Without Cable)

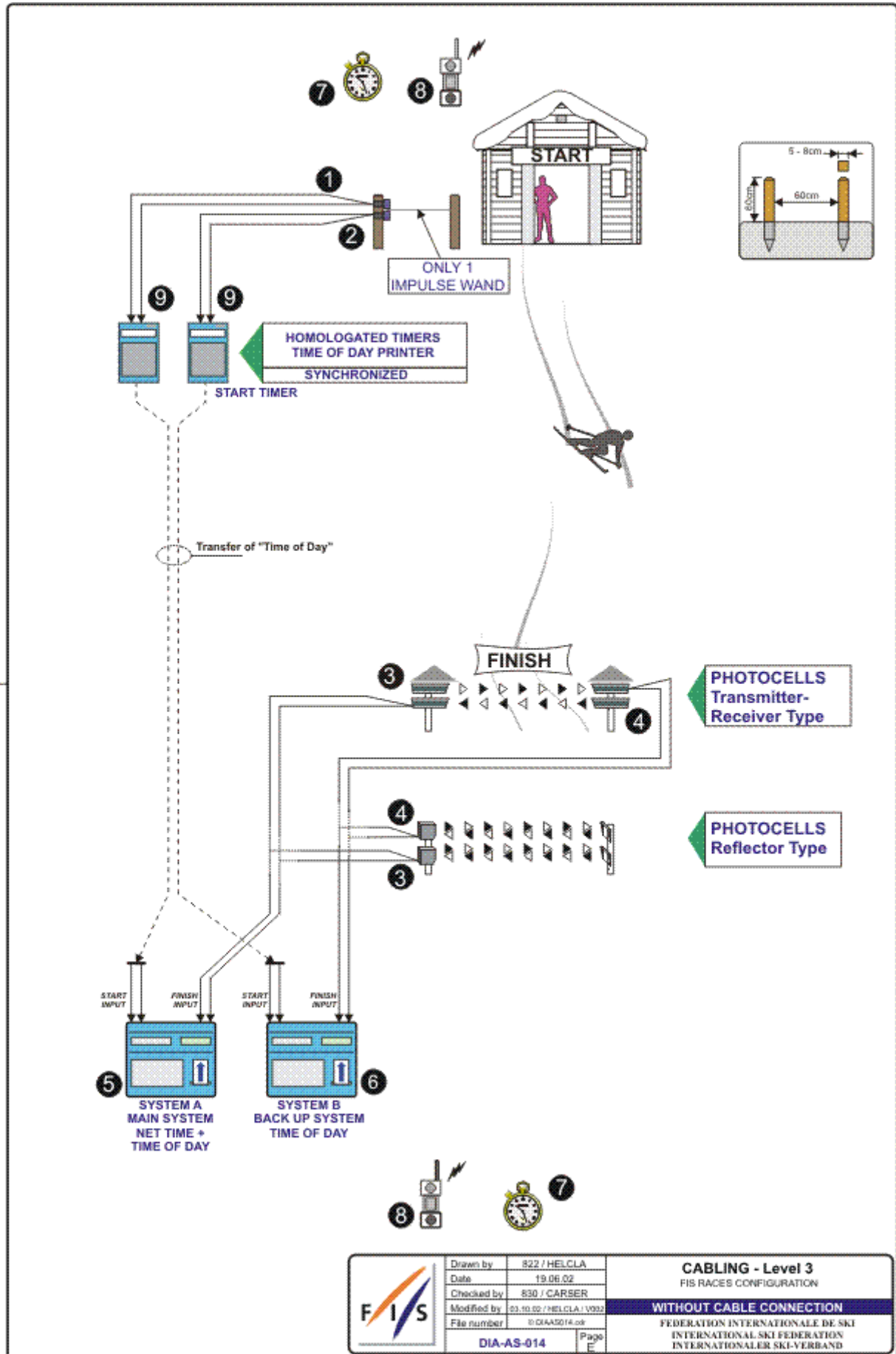

ICR 611 - Technical Installation

611 Technical Installations

611.1 Communications

In all international competitions, there must be multiple communication (telephone or radios, etc.) between the start and finish. Voice communication between starter and finish must be assured by fixed wire connection or radio. In case of radio, this must be on a separate channel from that used by any other function of the ROC. In Olympic Winter Games and FIS World Championships the communications between start and finish must be assured by fixed wiring. Except as set out in 611.2.4, all other methods of electronic timing e.g. transmission by radio are forbidden.

611.2 Timing Equipment

For all events in the FIS Calendar, electronic timing systems approved by the FIS must be used. A list of these approved devices will be published. Races using timing devices other than those on the approved FIS list will not be considered for FIS points.

Specifications and procedures for timing are more fully described in a separate FIS Timing Booklet.

611.2.1 *Electric Timing*

For all international competitions, FIS World Cup, FIS Continental Cups and FIS competitions, two synchronised electronically isolated timing systems operating in time-of-day must be used. One system will be designated system A (main system), the other system B (back up system) prior to the beginning of the race. All time of day times must be immediately and automatically sequentially recorded on printed strips to at least the 1/1000th (0.001) precision. Both systems must allow for the calculation of net times by the mathematical comparison of each racer's start time to finish time. The final result for each skier's run is then expressed to 1/100th (0.01) precision by truncating the calculated net time on course.

All times used for the final result must be from system A. If there is a failure of system A, a calculated net time from system B must be used following the same procedure as set out in 611.3.2.1. It is not permitted to substitute time-of-day times from system B for use with system A for the purpose of net time calculations.

For all events, system A must be connected to its respective start gate contact by hard wire connection. System B must be connected to another electronically isolated start gate contact by another separate pair of wires.

Refer to the FIS Timing Booklet for more details regarding cabling and complete wiring descriptions, diagrams and start gate installations.

All timing equipment and technical installation should be set up or protected in such a way that danger to the competitors is avoided where possible.

Synchronisation of the two timing systems must occur within 30 minutes of the start of each run. Synchronisation of the two systems must be maintained throughout the competition. Timers may not be re-synchronised during any run.

611.2.1.1 *Start Gate*

The start gate must have separate electronically isolated switch contacts for

triggering the start inputs of both system A & B.

If a start gate requires replacement during a run, it must be replaced with an identical start gate in the same position

611.2.1.2 *Photocells*

For all events, there must be two photocell system(s) approved for use by the FIS installed at the finish line. One is connected to system A. The other is connected to system B.

Procedures and regulations for start wands and photocells are found in the FIS Timing Booklet.

611.2.2 *Hand Timing*

Manual (hand) timing, completely separate and independent of the electronic timing, must be used for all competitions listed in the FIS Calendar. Stopwatches or hand-held battery operated timers that are installed at both the start and the finish and capable of expressing times to 1/100th (0.01) precision qualify as proper hand timing devices. They must be synchronised prior to the start of each run, preferably with the same time-of-day as system A and system B. Printed records, either automatic or hand-written, of recorded hand times must be immediately available at the start and at the finish.

611.2.3 *Score-board*

Organisers shall provide appropriate facilities for continuous visual or acoustic presentation of all registered times of all competitors.

611.2.4 *Radio Transmission*

For International FIS events only, it is permitted to use radio transmission systems as approved for use by the FIS for system B connection to the start.

611.3 **Timing of Finish**

611.3.1 With electronic timing, the time is taken when a competitor crosses the finish line and triggers the beam between the photo cells.

In case of a fall at the finish, the time can be taken without both of the competitor's feet having crossed the finish line.

For the registered time to become valid, the competitor must immediately completely cross the finish line with or without skis. With hand timing the time will be taken when any part of the competitor crosses the finish line.

The finish controller determines the correctness of passage across the finish line.

611.3.2 In the case of a failure of the main electronic timing system (system A), the results of the electronic back-up system (system B) will be valid as per art.

611.2.1. For the Olympic Winter Games, FIS World Ski Championships and FIS World Cup, a synchronised electronic timing system with printers, connected to the starting gate and to the photocells at the finish is obligatory.

In case of a failure in the lines of the timing system between start and finish, this back-up system will allow the calculation of the times to 1/100ths of a second.

In the case that calculated net times from either system A or system B are not available for a competitor, the calculated net manual time as per art.

611.3.2.1 will be considered valid.

611.3.2.1 *Utilisation of times taken by hand*

Hand times may be used in the official results after a correction has been calculated.

- Calculation of the correction

Calculate the difference between the times taken by hand and the electronic times of the 5 competitors starting before the missing time and the 5 starting after or if necessary the 10 nearest competitors.

The sum of the 10 time difference is divided by 10 to give the correction which must be applied to the hand time of the competitor without an electronic time.

611.3.3 The official timing strips from the printer will be given to the Technical Delegate. They will be kept until the official approval of the race or after any appeal dealing with timing or race results.

A technical timing report form as prescribed by the FIS must accompany the race results and must be reviewed and signed by the chief of timing and reviewed and signed by the TD as his approval of the race.

All printed records from system A, system B and hand timing must be retained by the ROC for a period of three (3) months after the competition or after any appeal dealing with timing or race results.

611.3.4 When the official printing timer allows manual input or correction of a time, some type of indication (star, asterix or other) concerning any effected change must be printed on all timing documentation.

611.3.5 Computer software calculating net times must use the precision of the time of day as used in the timing device.

611.4 Private Timing Equipment of the Teams

Any request to install timing equipment has to be made to the Jury by the team captain concerned, and the Jury decides concerning approval of the installation.

At Olympic Winter Games, FIS World Ski Championships and FIS World Cup only the organisers timing equipment is allowed.

Start Gate

Install the Start Gate in close co-ordination with the Technical Delegate and/or the Race Jury. Only Start Gates homologated by the FIS are allowed (see section of homologated timing equipment in this booklet and on the FIS website).

The following elementary rules should be considered:

- Start Gate mounting post must be put into the ground or snow or firmly connected to a fixed structure under the snow. It is essential that the support post be solidly fixed and not permitted to move in any way.
- The Start Gate must likewise be attached to the mounting post without the possibility of rotation or movement of any kind.
- The height above the ground of the Start Gate must be such to permit the athletes to hit the bar below the knee not too close to the boot top. In all cases the range shall not be less than 35cm nor more than 50 cm above the snow surface at the start.
- The start gate may be placed either to the left or right of the starting skier, in all cases making sure that the angle of departure to the first gate ensures that the start gate must open.

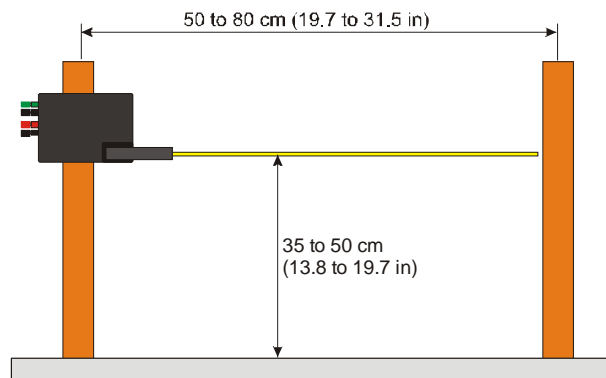

- The length of the wand (bar) must be within 50 cm (20 in) and 80 cm (31,5 in)
- The Start Gate must have two different and completely isolated lines, two separate connectors, one for timing system A and one for timing system B

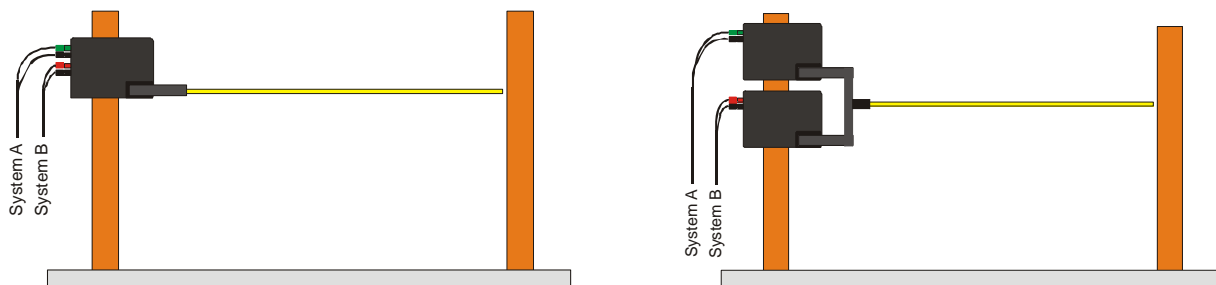

- If two Start Gates are used in concert, they must be solidly mounted on the same physical bracket and each arm must be stiffly connected together (both mechanism and box)
- Only the use of one wand (bar) is permitted
- If the Start Gate has to be replaced during the competition, it must be a Start Gate of the same type and manufacturer
- The position of the Start Gate (both height and rotation) must be marked before the beginning of the competition in order to make sure that a replacement can be installed in the same position if necessary

Technical Specifications for Start Gates :

Only Start Gates that meet the following technical specifications will be homologated by the FIS:

Contacts:

The Start Gate shall provide a separate contact for system A and B. Each contact needs a separate, but identical switch. Both contacts must be completely electrically separate and yet trigger at the same identical opening angle.

Angular Range:

Both impulses must be given at an angular range of the start wand between 10° and 30° , calculated from the closed position (when the wand is stiff). Starting gates that do not meet this trigger angle are not admitted.

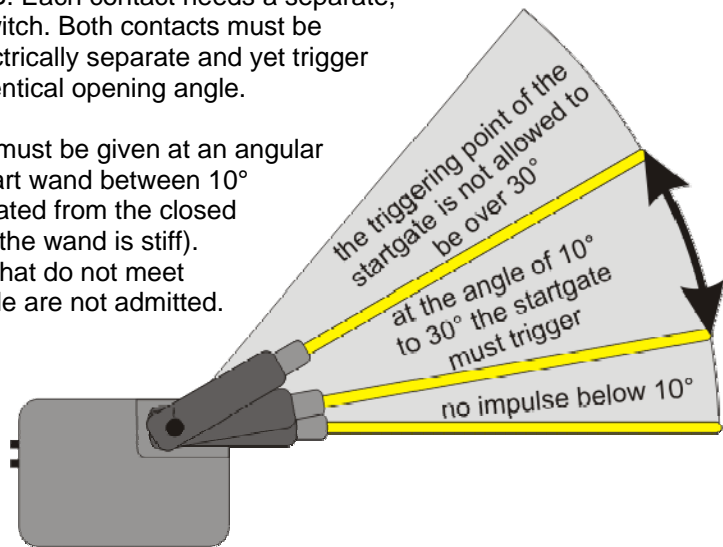

Angular Accuracy:

Both impulses shall be given by starting gate switches of the same type with an angular accuracy of $\pm 5^\circ$ respect to the indicated rotation of the start wand.

impulse tolerance is $\pm 5^\circ$ from the indicated value for the same startgate type

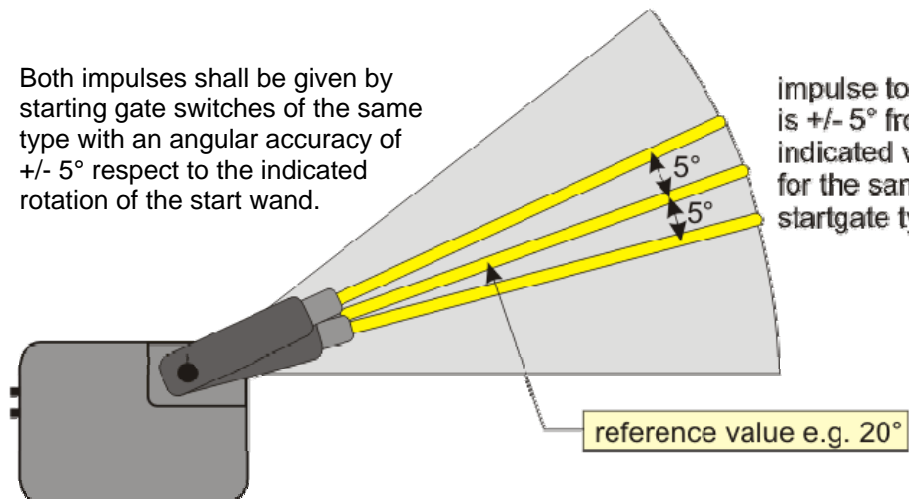

Start Wand:

The start wand cannot be so stiff that it could cause injury and that it will not break. On the other hand it must be as stiff as possible to avoid unfair starts. If you rotate the start wand at the far end, it is not allowed to bend more than 15° without causing the triggering mechanism to actuate. The wand must stay open once it is activated. Spring return "Self-Returning" mechanisms are not permitted.



Start Gate Impulses:

Two different possibilities are accepted:

- 1) **Single Shot:** the line is activated for predetermined time even if the wand remains open
- 2) **Continuous:** the line remains activated as long as the wand remains open.

Photocell

Install photocells in close co-ordination with the Technical Delegate and/or the Race Jury. It is strongly recommended that the approach to the finish and the width of the line be made as level as possible, making it virtually impossible for athletes to slide under or jump over the beams when installed.

Only wooden posts with a maximum diameter of 6 cm should be used to mount the photocells at the finish. You should cut the wood posts so they can break away in case of being struck by a racer. This cut must be made facing uphill. All brackets and elements of the photocells should be placed on the downhill side of the post. If photocells for intermediate are used they should be mounted on hinged poles that will break away.

Photocell system A and B must always be completely separate (separate case and mounting brackets).

For photocells appropriate protection must be provided by the organizer.

Only photocells homologated by the FIS are allowed to be used for the finish (see section of homologated timing equipment in this booklet or on the FIS website).

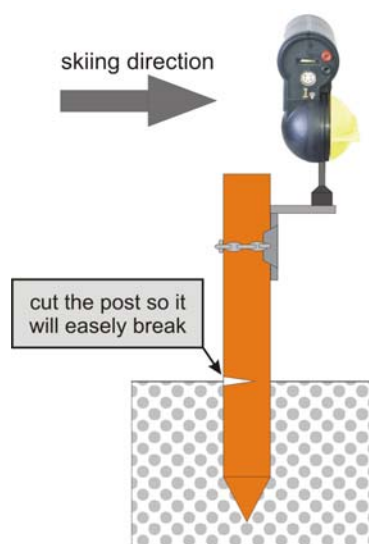

There are two categories of cells:

1. Reflector Type:

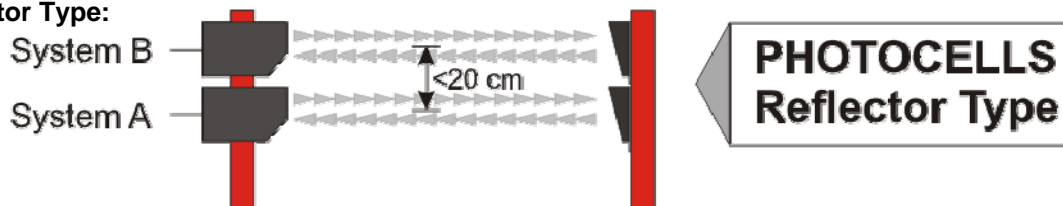

The reflector-type photocell has the transmitter and receiver electronics in the same case. A simple reflector on the opposite side of the finish line is used to reflect the photocell beam back to the main unit. For System A and B the reflectors should be on the same side.

2. Transmitter-Receiver Types:

In this case the transmitter is on one side of the finish, and the receiver is on the other side. For System A and B transmitters can either be on opposite sides or on the same side.

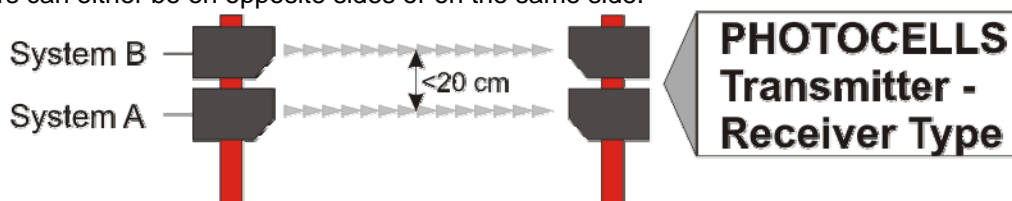

Photocells for the Finish:

It is necessary to have two independent sets of photocells for the finish, one connected to Timing System A and one for Timing System B. The cells must be mounted so that both beams are triggered at a height that is lower than the knee of racers at the finish. It is recommended that the lowermost photocell be connected to Timing System A.

The photocells must be set up parallel to the finish on top of each other. Either the same post or two separate posts for both photocells can be used. The maximum vertical separation of the beams may not exceed 20 cm (8"), and in all cases should be less than that if possible.

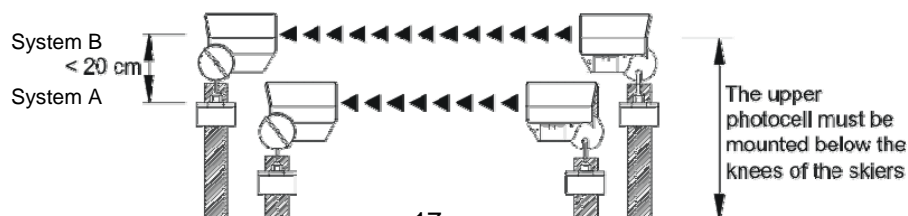

For the Transmitter-Receiver Type the Transmitters of the photocell can be either on the same side or opposite side (see manufacturer specifications). The beams may be installed in a crossed configuration but in all cases the 20cm maximum vertical separation must be observed.

The photocells must be connected to the timing devices by fixed cable. No radio transmission of photocell signals to the timers is allowed for the finish photocells.

Photocells for Intermediate Time:

There is no requirement to have a back up (System B) photocell for the intermediate time.

If you use photocells install them in close co-ordination with the Technical Delegate and/or the Race Jury.

To avoid the photocells (if used) being triggered by anyone other than the competitors, it is recommended that the person responsible for that intermediate timing point use a push-button to arm the photo cells only when a competitor crosses the line.

Technical Specifications for the Photocell

The technical concept of the photocell is not restricted by the FIS, although it must be assured that the photocell cannot be influenced by any other light, camera flash/strobes, radio waves (EMI) or mobile reflectors for photocells of reflector type.

The photocell must meet the standards for electronic devices in the country that it is sold.

Accuracy:

Sensing Time - The time delay from the instant the photocell is triggered to moment an output impulse is generated may not exceed 0.005 sec.

Repeatability (Random Jitter) - The delay of impulses must be constant, the range must be less than 5/10.000 sec. This range is measured in a "peak-to-peak" manner, minimum to maximum extremes, it is not averaged.

Operating Distance:

The photocell must work over a minimal distance of 20 m. The maximum size of the reflector (if used) is 100 mm (in all directions).

Triggering Object:

An 8 mm object moving with a speed of 10 km/h is not allowed to trigger the photocell (measured at a distance of 2 m from lens of the receiver).

A 100 mm object moving with a speed of 200 km/h must trigger the photocell (measured at a distance of 2 m from lens of the receiver).

Temperature Range:

-20 to 50°C (for colder weather you should prepare a cover so the photocell will still work).

Power Supply:

If the photocell is supplied power from the timing device (within the same cable as the impulses) it needs no external power supply.

If a battery is used as the power supply (external or internal) the Photocell must work for four (4) hours at -20°C.

For homologation of photocells

When sending photocells to the FIS for homologation, the photocell needs an input contact to switch the photocell transmitter off, in order to make precise tests

“How-To” Explanation Text Timing Technical Report Form

Version 6.4, Season 2006-2007

The FIS Alpine Timing Technical Report Form is a required document that must be correctly completed and submitted with all race results for all alpine events in the FIS calendar. Events that do not submit this form, duly completed, will not be considered for FIS points.

Technical surveys conducted by the FIS since 1995, and the mountain of timing evidence collected by the Timing Working Group during this period led to the introduction and ongoing use of this form. It is a valuable tool and audit document. There is without a doubt a need to have all information concerning the correct determination of an event by the timing equipment, and techniques being used, properly indicated on the Timing Technical Report Form.

An annual summary of the data from these forms is conducted. Although the vast majority of FIS events are conducted correctly, the form asks questions that can only be replied to if certain minimum technical standards are met. It ensures that at least two homologated, synchronized Time-of-Day systems, plus hand timing are used, and it makes you pay attention to the details of how well the systems operate together. The Timing Technical Report Form minimizes errors and is designed to assist you to make the event fair for all who take part.

Please take note: For all events with two runs, re-synchronization of the timers must take place before the start of the second run.

This document represents a step-by-step explanation of what is needed in each square of the Timing Technical Report Form 6.4. Since some of the information being provided will most likely remain consistent (example: equipment being used, equipment serial numbers, event locations...) you can fill out most of this information once and then make photocopies or a computer file if you use the same items throughout all of your competitions.

Notes and Suggestions:

Quite fortunately, alpine ski racing is judged purely from the standpoint of objective criteria. Make it through the course correctly, and a skier is judged by the passage of time alone. The Homologated Timing Equipment list that is approved by the FIS, the rules described in section 610 of the ICR, and the use of the Timing Technical Report Form ensure that many common mistakes that can jeopardize the simple truth of this timing judgment are minimized or avoided.

We are certain that your attention to detail in this regard will contribute to a successful event and we extend our thanks and best wishes for the serious work that you undertake for the benefit of ski racing world-wide.

Codex:

All events in the FIS Calendar are assigned a code number so that they can be correctly identified. This race ID code number is called the „CODEX“ and there is one codex for each race that is assigned by discipline and sex. The Codex for your race is found in the FIS Calendar. It must match the Codex number used on your Official Results. Do not include information other than the four-numeric-character code.

Example: 0321

Location:

Use the location as described in the FIS Calendar, or if the event has been moved, the name of the ski area you are at. Include discipline, Nation and race gender information, using the DH/SG/GS or SL and Men / Women indicators as appropriate.

Example: WINTER PARK COLORADO GS: X Nation: USA MEN: X

Event Name:

Enter the same name of the event as it is described in the FIS Calendar and on your Official Results documents. Include category details.

Example: DU FISU

Date:

The FIS uses the dd/mm/yy format.

The following section identifies the timing equipment you use at your race.

Brand:

This is the brand name of the manufacturer.

Examples: Longines / ALGE / TAG Heuer / Seiko /

Model:

This is the model name of the particular device you are using.

Examples: TL5005 / TdC 8001 / CP 505 / MT 400 /

Serial Number:

Each device should have a manufacturer's serial number. This is found in a variety of places on timing equipment depending on the model and manufacturer. If not found on the bottom, rear or side of the device, check inside the printer or battery compartment. Contact your manufacturer or agent for complete information and have it handy. If one cannot be found, a number should be assigned and marked on the device.

Homologation #:

The FIS issues a list of timers, start gates and photocells that have met the technical standards required for use at FIS events. **Only timing equipment on the approved list may be used at any and all alpine FIS races that appear in the FIS Calendar.** A new list may not be printed each season, rather The Timing Booklet will be published from time to time and additions or deletions to the list of homologated timing equipment will be contained in the precisions to the FIS rules published each fall. **In all cases you can find all updated information on the FIS website at www.fis-ski.com.** Failure to use equipment on that list will cause your event not to be considered for FIS points. Each piece of approved timing equipment will have a code number associated with it. A complete list of those codes can be found in the Homologated Timing Equipment List. Use the appropriate code number for the approved device you are using.

Example: TAG.001.99

Sys A Timer:

This is the Main Timing System Timer at finish

Sys B Timer:

This is the Back-Up Timing System Timer at finish

Start Gate:

Describe the homologated start gate you used with the name of the manufacturer and model designation. Include the serial number and homologation code.

Finish Cells:

Describe the homologated Finish Cells of Systems A and B using the name of the manufacturer and the model designation. If different models are used for the A or B system, describe them both. Include serial numbers and homologation codes.

Connections to Start

This section deals with how your **connections to the start** were made for both the Main (System A) and Back-Up (System B) timers, and how you handled the voice communications requirements. In the boxes, insert the method used based on how you set up the two systems and the voice communication. Use the word "Cable" or indicate how the start time data was transmitted or carried to the timer at the finish.

Time Data Section

This is the section that provides the proof that your two systems and hand timing were synchronized and functioning as required by the rules. There are 15 pieces of information for each run that you can get only from the timer tapes and that allow the FIS to see that you did the timing correctly. Two other times come from Hand timing data. Be prepared to gather this information from the timer tapes as it happens, or at least to know where to find it after each run. It is critical that this information be correctly retrieved and indicated on the form

POWER ON Time (warm-up):

Every timing system needs a period of time for the quartz time base to stabilize after the timer is first switched on. This box is provided to remind you to do so in advance of run synchronization (Recommendation: at least 30 minutes prior to synchronization). Four places are available for indications of up to the four timers required for use if no hill cable is used. F is for the timers at the finish, S is for those at the start (if used).

Indicate the Time of Day this was done.

Synchronization Time:

Once System A and System B are set up and turned on, the rules require that they all be synchronized to the Time of Day no more than 60 minutes before the start of each run. Indicate the time of day the timers were preset to and synchronized at. This Time of Day must appear on the System A and System B Timing Tapes. This should be done by using the start gate as the triggering source for all systems at once. In all cases all systems should be triggered by one synchronizing contact.

Indicate the Time of Day this was done.

Example: 10:00

Synch confirm at +1 minute:

Once synchronization to the Time of Day for all systems has been accomplished, have the starter open the start wand again (or use the same synchronizing contact) after 1 minute has elapsed since the synchronization. Observe the times recorded on all systems and make sure the System A and System B timers are truly running at the same time of day and are giving you very similar times from the triggering of the start. At Synchronization time plus 1 minute, the times you get on each system should be identical, or be within a few 1/1000ths (0.001 sec.). If they are not, you must re-synchronize and try again. Note that four spaces are provided for indications about synchronization of the four required timers when events are being timed without hill cable. F is for the timers at the finish, S is for those at the start (if used).

Indicate the actual readings in Time of Day (TOD) you take from the System A and System B tapes to the 1/1000th of a second or better (same precision as printed on the timing tape).

Example: 10:00:51.225

Start TOD First Competitor*: give the Start Time of Day from the first competitor to finish his run.

Finish TOD First Competitor*: give the Finish Time of Day from the first competitor to finish his run. Show bib.

Start TOD Last Competitor*: give the Start Time of Day from the last competitor to finish his run.

Finish TOD Last Competitor*: give the Finish Time of Day from the last competitor to finish his run. Show bib.

This data section has on the left side space to insert the times of the first run, and on the right side space for the second run. These 8 boxes provide locations for the readings from the two systems of the start and finish times of your first and last racers who make it through the course. **Insert the Time of Day Times that are recorded on the System A and System B tapes for these racers to the 1/1000th (0.001) of a second or better.** Note that there are spaces for indicating what the bib numbers of the particular racers used in your samples were. Use only the first and last skiers who finish having **complete timing data**.

Net Time:

These 4 positions are used to indicate the actual elapsed net times on course for the two samples of the first and last racers on course who made it to the finish, as recorded on System A. **These must be identical to the net times used on the results, and are indicated to the 1/100th (0.01) of a second.** This allows you to check if the calculation of the net times on course, as derived from the Time of Day times recorded to 1/1000ths on the System A tapes, was done correctly. Times are expressed in Min/Sec/100ths. You should also use this as an opportunity to check that the times used on the results match those calculated from the timer tapes.

Example: 1:00.91

Hand Time:

Hand Timing is mandatory for all events in the FIS Calendar. These positions allow you to provide the evidence that hand timing was used and how well it was done. The hand times used here are net times on course calculated from the Time of Day start and finish times your hand timers record. Calculate the elapsed hand times on course for these athletes and indicate them here. The Net Time of the Hand Time should be comparable (no big time difference).

Best run-time System A:

Indicate the fastest time obtained in that run and which bib it was assigned to.

Were all times from system A?:

Indicate if all racers were timed during this run using System A as required by the FIS Rules. Check the appropriate box „yes“ or „no“.

List any or all bib numbers used in the results timed on any system other than system A in all runs (indicate run)

If you answered „No“ in the section above, list the bib number(s) of the racer(s) and the respective run number, who were timed on System B or using Hand Timing for each **replacement System A time calculation**. Indicate the reason for the problem(s) and describe it.

Comments:

Describe any problems or comment upon corrective actions that were necessary during the timing of any run held during this series. Obviously if you have any racers who have times used on the results from anything other than System A, you should explain this here. The TD should indicate if any timing component used requires verification or service before the next event. This provides the opportunity to indicate if any of the equipment, wiring or other components requires service or corrective actions before the next event. This could apply to staff and procedures as well as equipment. This can include comments even if all times were derived from System A.

We certify that the timing and calculations of this event adhered to the rules.

This is a direct statement that requires a “yes“ or “no“ answer.

Both the FIS Technical Delegate and the Chief of Timing must review and complete this documentation and attest to the accuracy of the information contained herein. Print and sign your names and provide the other **details requested**.

Chief of Timing and Technical Delegate:

Both have to confirm the given data by signing. Please give your e-mail address and phone number in case of questions!

Timing Technical Report Form (example)



Timing Technical Report

Alpine

CODEX example 0247

0321

To accompany TD Report immediate transmittal - One form required for each Codes

Version 6.41

Location:	Vilamoura	DH <input type="checkbox"/> SL <input type="checkbox"/> GS <input checked="" type="checkbox"/> SG <input type="checkbox"/> SC <input type="checkbox"/>
Nation:	Portugal	MEN: <input checked="" type="checkbox"/> LADIES: <input type="checkbox"/>
Event Name:	FIS Congress Challenge	
Date (dd/mm/yy):	23.05.06	

	Brand	Model	Serial Number	Homologation #
Sys A Timer:	ALGE	TdC 8001	200604-92	ALG.003.02
Sys B Timer:	LONGINES	TL5005	9905-120	LON.003.97
Start Gate:	MICROGATE	MIC.S66.03	0008-12	MIC.956.03
Finish Cells A:	TAG Hauer	HL2-33	0303-121	TAG.L50.03
Finish Cells B:	Seiko	PBU-S10	0503-128	PBU-S10

Connections to Start	System A	System B	Voice Comm.
Cable, Radio or other (Specify)	Cable	Cable	Radio

POWER ON Time (warm-up): 07:00 At least 30 minutes before Synchronization.

Time of day expressed in thousandths.	1st Run			2nd Run		
	System A (TOD) #	System B (TOD) #	Hand Sync.	System A (TOD) #	System B (TOD) #	Hand Sync.
Synchronization Time	09:15		09:15	12:00		
Synch confirm at +1 minute	9:16:02.3423	9:16:02.341		12:01:02.3423	12:16:02.341	
Start TOD First Competitor *	9:30:01.2942	9:30:01.294	Net Time	12:30:01.1421	12:30:01.142	Net Time
Finish TOD First (1) (23) *	9:31:30.4269	9:31:30.434	1:29.43	12:31:30.4932	12:31:30.492	1:29.34
Hand Time First Competitor *			1:29.48			1:29.41
Start TOD Last Competitor *	11:03:00.2543	11:03:00.253		13:05:00.3214	13:05:00.322	
Finish TOD Last (75) (2) *	11:04:35.5964	11:04:35.597	1:35.34	13:06:29.5479	13:06:29.547	1:29.22
Hand Time Last Competitor *			1:35.49			1:29.29
* First and Last to Finish with complete data.						
Best run-time System A		Bib : (2)	1:29.25		Bib : (2)	1:29.22
Were all Results from system A?	Indicate <input checked="" type="checkbox"/> Yes <input checked="" type="checkbox"/> No		# TOD seconds in thousandths, at least			

List any or all bib numbers used in the results timed on any system other than system A in all runs (indicate run):

WHY? Batteries Snow obscuration Wire break Photocell alignment Other? (describe)

For BIB 25 the system A photocell was moved by the finish judge by accident, but the time from the system B photocell system was OK

Data Source for replacement system A time. (resp. ICR 611.2.1) ?

BET has been calculated and from system B

Comments:

We certify that the timing and calculations of this event adhered to the FIS rules.
YES: X NO: O

Chief of Timing - Name (Print)	Email, Telephone	Signature	
Allen Church	alcm@home.veg.com +1-402-3347897		
Technical Delegate - Name, HAT (Print)	Email, Telephone	Signature	FIS TD#
Dave Pym	davepym@gmail.com +1-402-4973774		234

Download this form from www.fis-ski.com



Timing Technical Report

Alpine

CODEX example 0247

To accompany I/O Report Immediate transmittal - One form required for each Codex

Version 6.41

Location:	DH <input type="checkbox"/> SL <input type="checkbox"/> GS <input type="checkbox"/> SG <input type="checkbox"/> SC <input type="checkbox"/>
Nation:	MEN: <input type="checkbox"/> LADIES: <input type="checkbox"/>
Event Name:	

Date (dd/mm/yy):	

Connections to Start:	System A	System B	Voice Comm.
Cable, Radio or other- (Specify)	-	-	-

POWER ON Time (warm-up): At least 30 minutes before Synchronization.

Time of day expressed in thousandths.	1st Run			2nd Run		
	System A (TOD) #	System B (TOD) #	Hand Sync.	System A (TOD) #	System B (TOD) #	Hand Sync.
Synchronization Time						
Synch confirm at +1 minute						
Start TOD First Competitor *			Net Time			Net Time
Finish TOD First () () *						
Hand Time First Competitor *						
Start TOD Last Competitor *						
Finish TOD Last () () *						
Hand Time Last Competitor *						
* First and Last to Finish with complete data.						
Best run-time System A	Bib : ()			Bib : ()		
Were all Results from system A?	Indicate	<input type="checkbox"/> Yes	<input type="checkbox"/> No	# TOD seconds in thousandths, at least		

List any or all bib numbers used in the results timed on any system other than system A in all runs (indicate run):

WHY? Batteries Snow obscuration Wire break Photocell alignment Other? (describe)

Data Source for replacement system A time. (resp. ICR 611.2.1) ?

Comments:

We certify that the timing and calculations of this event adhered to the FIS rules.

YES : NO :

Chief of Timing - Name (Print)	Email, Telephone	Signature	
Technical Delegate - Name, NAT (Print)	Email, Telephone	Signature	FIS TD #

Download this form from www.fis-ski.com

Criteria for FIS Approved Timing Devices for Alpine Ski Races

All timing devices must meet the following criteria for use in FIS Alpine races, and that are manufactured after May 1997.

- Timer:** The timing device must have an internal, or external printer. Printing through a computer is not allowed.
- The timer must be able to operate in Time-of-Day. The output of the time must always have the same precision (e.g. printer, display, interface).
- Printer:** This printer must print at least in a chronological order the time of day.
- For each printed time of day there must be an indication of the timing channel.
- If it is possible to do manipulation or correction of times in the timer the printer must mark such a corrected time.
- Interface:** The timing device needs an interface (e.g. RS232, RS422, USB) to connect a PC and transfer the data for data processing (result service) online.
- Power Supply:** The timing system must work without power supply from the mains for four (4) hours at 25°C and one printout per minute and two (2) hours at -10°C and one printout per minute.
- Operation Temperature:** The timing device and printer must work at ambient temperatures from -10° to +40°C
- Measuring Range:** Time of day mode must be possible in hours, minutes, seconds and 1/1000, or better.
- Timer Precision:** Must measure up to the 1/1000 second in time of day mode
- Timer accuracy must be below +/- 10 PPM at a device temperature from -10° to +60°C.
- Quartz:** Ageing of the quartz must be below +/- 3 PPM per year.
- With adjusted quartz frequency the time drift must be below +/-0.5 PPM at 25°C.
- Impulse Triggering:** The delay of impulses is not allowed to be higher than 1/1000 sec.
- The delay of impulses must be constant, the range must be less than 1/10000 sec.
- Timing Channels:** The timing device needs a minimum of two independent channels, one for start and one for finish.
- Synchronisation:** Synchronisation between main- and backup timer must be possible.
- Electromagnetic:** The timing device must meet the standards of IEC (International Electronic Commission). This means the timing device must function satisfactorily in its electromagnetic environment without introducing intolerable electromagnetic disturbances to anything in that environment.
- Truncation:** The truncation to 1/100 of seconds must be made after the calculation of the run time. The digits of the run time after the 1/100 are thrown away.
- e.g.:
- | | |
|----------------------------|--------------|
| Start Time: | 10:00:00.132 |
| Finish Time: | 10:01:30.259 |
| Calculated Run Time: | 1:30.127 |
| Run Time after truncation: | 1:30.12 |
- Homologation:** Manufacturers wishing to have their timing devices, start gate or photocell homologated for use in FIS races must supply all technical information indicated above to the „FIS Timing Working Group“ c/o Francesco Cattaneo at the FIS Office in Oberhofen Switzerland (cattaneo@fiski.ch). The costs of homologation has to be paid by the manufacturer.



Homologated Timing Equipment Tested by FIS Timing Working Group Approved by FIS Rules Committee



List valid as of 23.05.2006 - check www.fis-ski.com for latest version
(see Rules and Publications / Alpine Skiing / Alpine Timing)

Timers

ALGE	ALG.001.97	TdC 4000	
	ALG.002.97	TdC 8000	
	ALG.003.97	COMET	<i>With external printer</i>
	ALG.004.97	S3	<i>With external printer</i>
	ALG.005.97	S4	<i>With external printer</i>
	ALG.001.02	Timy PXE	
	ALG.002.02	Timy XE	<i>With external printer</i>
CAHOUR	ALG.003.02	TdC 8001	
	CAH.001.97	DATA 2000	
	CAH.002.97	DATA 4000	
DIGITECH	DIG.001.99	MASTER	
HEGO	HEG.001.97	HEGO 6000	
	HEG.002.97	HEGO 7000	
	HEG.001.99	HEGO 8000	<i>With external printer</i>
LONGINES	LON.001.97	TL2000	
	LON.002.97	TL3000	
	LON.003.97	TL5005	
MIC	MIC.001.97	MTS 2000	
MICROGATE	MGA.001.97	REI	
	MGA.002.97	RACETIME2	
	MGA.001.00	REI 2	
OMEGA	OME.001.97	OGM5005	
	OME.002.97	OTR7	
	OME.003.97	POWERTIME	
	OME.004.97	ARES 21	
RADIOCOMS SYSTEMES	RAD.001.02	DATA SPRINT	<i>With external printer</i>
	RAD.070.06	DATA SPORT	<i>With external printer</i>
SEIKO	SEI.001.97	MT-400	
	SEI.002.97	CT-400	
	SEI.003.97	CT-300/CT-300II	
	SEI.004.97	CT.916/CT.916II	
	SEI.001.01	CT-1000	
	SEI.002.01	EUT-3000	
SUMMIT SYSTEMS	SUM.001.03	SRT1000	<i>With external printer</i>
TAG HEUER	TAG.001.97	CP 501	
	TAG.002.97	CP 502	
	TAG.003.97	CP 503	
	TAG.004.97	CP 505	
	TAG.005.97	PTB 605	<i>With external printer</i>
	TAG.001.99	CP 705	
	TAG.001.01	CP 520	
	TAG.001.02	Spillmaster HL 650	<i>With external printer</i>
	TAG.071.06	PTB 606	<i>With external printer</i>
	TELECHRON	TEL.001.97	DIGITIME
WIMTEC	WIM.001.98	TIME-MASTER/H	

Startgates

ALGE	ALG.S51.03	STScM2S
	ALG.S52.03	STSnQ
	ALG.S53.03	STSnM2s
LONGINES	LON.S57.03	B65
	LON.S58.03	CAP021
MICROGATE	MIC.S56.03	FIS
OMEGA	OME.S59.03	OSG2
SEIKO	SEI.S55.03	SG600
TAG HEUER	TAG.S54.03	HL7-1

Photocells

ALGE	ALG.L44.03	RLS1c
	ALG.L45.03	RLS1n
	ALG.L46.03	RLS1n RX
	ALG.L65.03	RLS1
	ALG.L66.03	RLS1c RX
MICROGATE	MGA.L69.03	FCT3
OMEGA	OME.L67.03	Translme
	OME.L68.03	OEC4
SEIKO	SEI.L60.03	PBU-600
	SEI.L61.03	PBU-601
	SEI.L62.03	PBU-700
	SEI.L63.03	PBU-710
	SEI.L64.03	PBU-800
	SEI.L65.03	PBU-810
TAG HEUER	TAG.L47.03	HL 2-31
	TAG.L48.03	HL 2-35 R-E
	TAG.L49.03	HL 2-32
	TAG.L50.03	HL 2-33

Conclusion

We hereby wish to thank all members of the "FIS Timing Working Group" who have always used every endeavour to realise this "FIS GUIDE" for their Technical Delegates and event organisers. Our progress since 1996 reflects the balance between accepting new technologies and ensuring the correct evaluation of human performance through fundamental timekeeping concepts.

We wish to acknowledge the major contributions of participating manufacturers, FIS professionals and volunteers from our many member National Associations and race organisers who give so much of their time and expertise without which it would be impossible to generate such a document or perspective.

The FIS is pleased to support such a unique group in the world of timekeeping regulation and notices the absence of similar structures in many other high-performance sports that rely so heavily on timing technology for fair and impartial judgement.

We are fully aware that there are still some imperfections in these rules and descriptions and would welcome any constructive proposal as the works proceed. This document will be continually revised to improve the knowledge of the FIS community for the benefit of all Alpine Skiing competitions.

Please contact us with your suggestions and comments:

Francesco Cattaneo (FIS – Chairman)	cattaneo@fisski.ch
Pierre Blanc (FRA)	pierreffs@aol.com
Serge Carnal (SUI)	serge.carnal@swisstiming.com
Allen Church (USA)	churchallenb@cs.com
Ted Savage (CAN)	tsavage@precisiontiming.com
Albert Vetter (AUT)	albert@alge-timing.com

FIS Timing Working Group